

**180-8124 Solder Terminal, Turreted
 Non-Magnetic**

Recommended mounting hole .064 (1,63), #52 drill

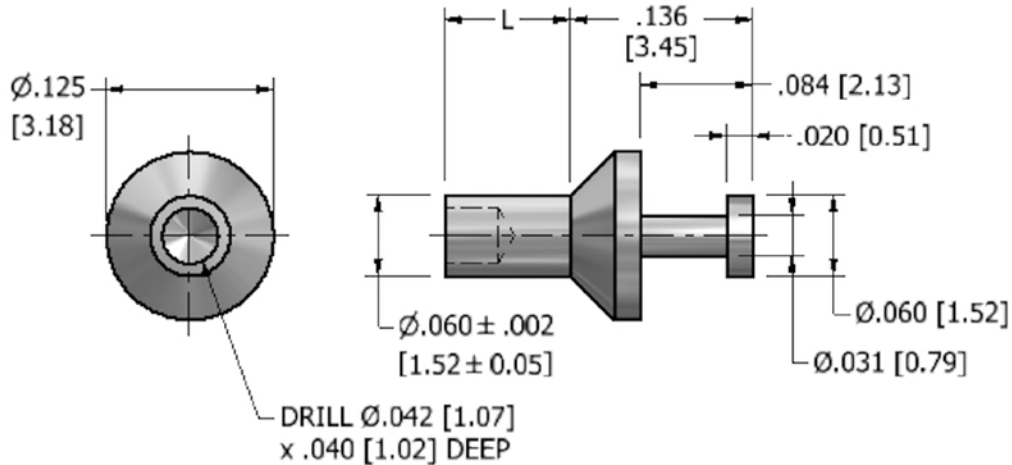

**How to order code
 180-8124-XX-YY-00**

Basic Part No XX = L dimension, YY = Plating Finish

DIMENSIONS (XX)			
Basic Part No	(XX)	L	Board Thickness
180-2753	-01	.062 (1,57)	.031 (0,79)
	-02	.094 (2,39)	.062 (1,57)
	-03	.125 (3,18)	.094 (2,39)
	-04	.156 (3,96)	.125 (3,18)

MATERIALS			
Component	Material	Finish (YY)	Finish (YY)
		-04	-05
Terminal	Brass, non-magnetic	Electro-Tin	Electro-Solder

SWAGE TOOLING	
Recommended Swaging Tools:-	
Anvil	435-6430-01-00-00
Flare Punch	435-6657-01-00-00

Dimensions in inches [mm]
 Tolerance unless otherwise stated ±.003 [0.08]