

**450-3756 Swage Mount Socket, for .040 (1,02) Diameter Pins**

Recommended mounting hole .067 (1,70) ± .002 (0,05), #51 drill

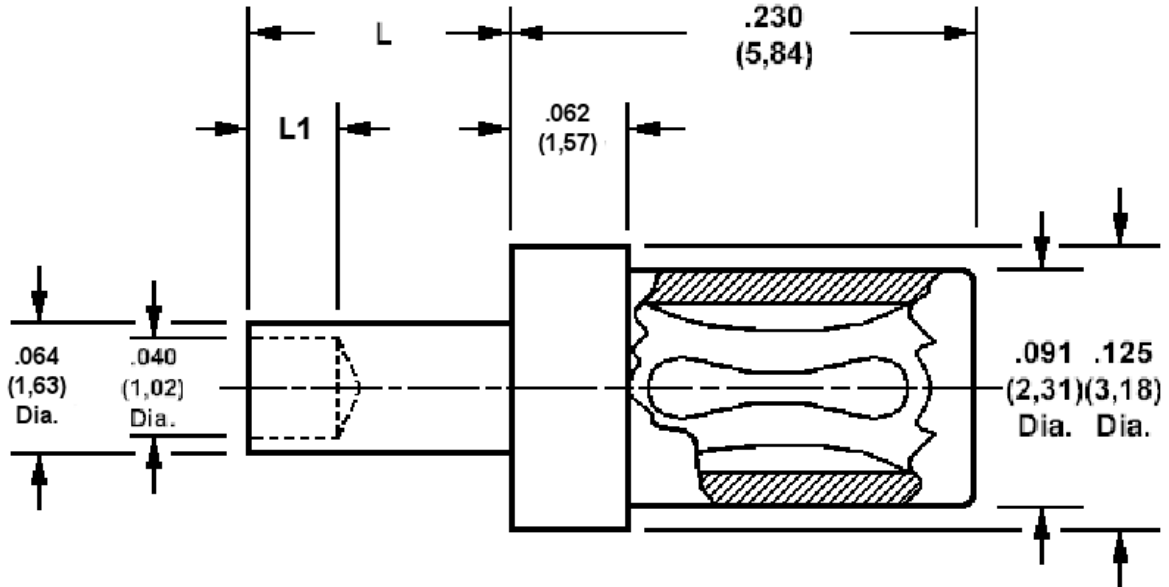

Min hole depth .180 (4,75)

**How to order code**

**450-3756-YY-XX-00**

Basic Part No YY = Board thickness XX = Finish

DIMENSIONS			
Dash No (YY)	'L'	'L1'	Board Thickness
-01	.062 (1,57)	.040 (1,02)	.031 (0,79)
-02	.094 (2,39)	.061 (1,57)	.062 (1,57)
-03	.125 (3,18)	.061 (1,57)	.094 (2,39)
-04	.156 (3,96)	.061 (1,57)	.125 (3,18)

MATERIALS				
Component	Material	Finish (-03)	Finish (-04)	Finish (-06)
Body	Brass	Gold over Nickel	Electro Tin	Electro Tin
Spring	Beryllium copper	Gold over Nickel	Electro Tin	Gold over Nickel

TOOLING	
Recommended Swaging Tools:-	
Anvil	435-6404-01-00-00
Roll punch	435-6642-01-00-00
Flare Punch	435-6657-01-00-00