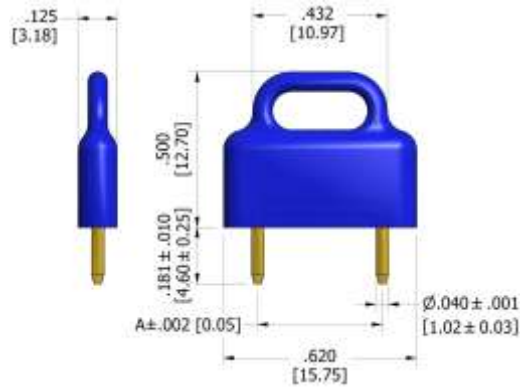

**461-8119 Shorting Links, Insulated, .040 (1,02) Diameter Pins  
Non-Magnetic**(For non-insulated version see 360-8118)  
(For smaller pitch between pins, see 461-8116)**How to order code  
461-8119-XX-YY-ZZ**

Basic Part No XX = A Dimension, YY = Plating Finish, ZZ = Colour

DIMENSIONS		
Basic Part No	Dash No (XX)	A Dimension
461-8119	-01	.400 (10,16)
	-02	.500 (12,70)

MATERIALS			
Component	Material	Finish (-03)	Finish (-04)
Pin	Brass, non-magnetic	Gold 0.75um over Copper	Electro-Tin over Copper
Insulator	Polypropylene	Select colour (see below)	

COLOUR (ZZ)		
-10	-12	-16
Black	Red	Blue

Dimensions in inches [mm]  
Tolerance unless otherwise stated  $\pm .010$  [0.25]