

558-7107, Variable Coil, Shielded, Vertical, .09µH thru 1.1mH (533-3652 Form)

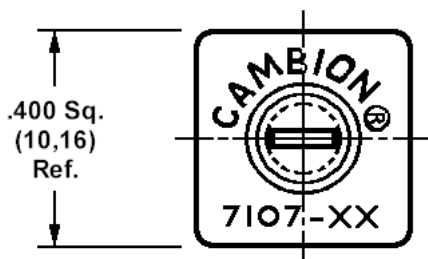

TOP VIEW

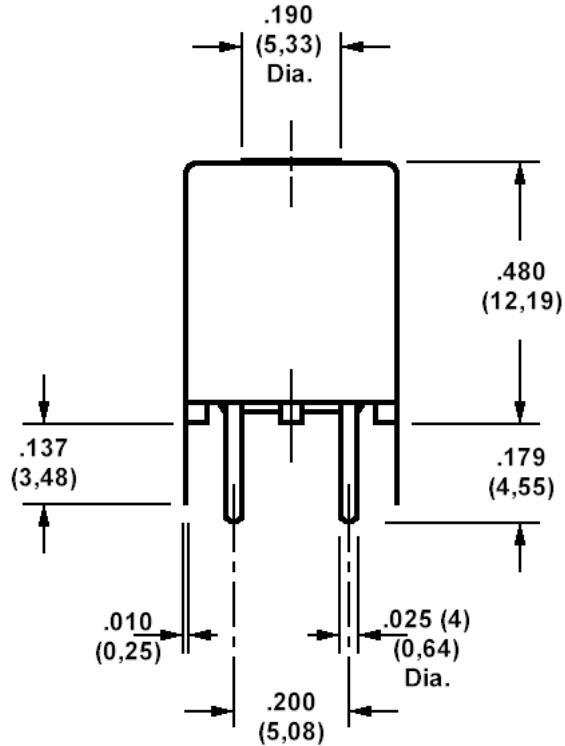
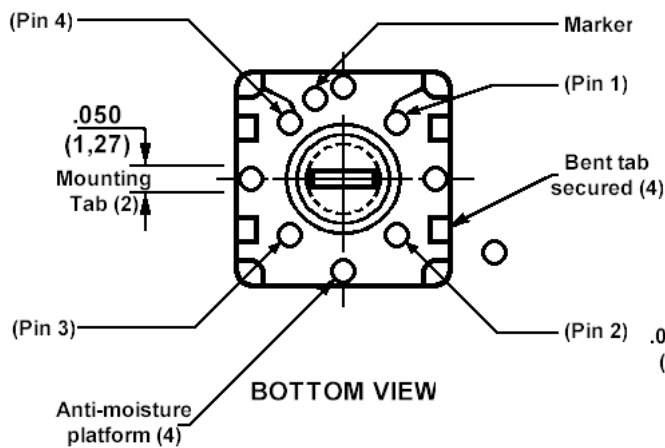
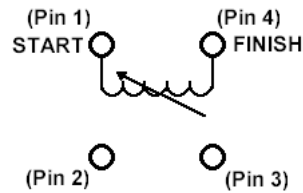

BOTTOM VIEW

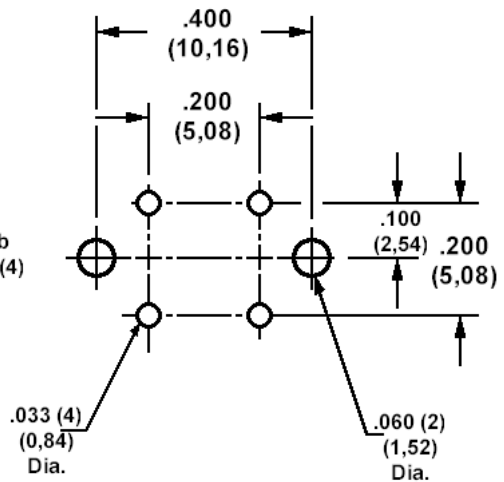

How to order code

558-7107-XX-00-00

Basic Part No (XX = Inductance range identifier. See table for options)

Basic Part No.	XX	Inductance L (µH)		Q Min. @ L Min	Q Min. @ L Max	Test Freq. (MHz)	DCR Max. (Ω)	DC Max. (mA)	SRF Min. (MHz)
		Min.	Max.						
558-7107	-01	.090	.110	65	65	25.0	.031	2200	250.0
	-02	.108	.136	65	65	25.0	.034	2100	250.0
	-03	.135	.165	70	70	25.0	.037	2000	250.0
	-04	.162	.198	70	70	25.0	.049	1750	250.0
	-05	.198	.245	70	70	25.0	.055	1600	250.0
	-06	.243	.297	70	70	25.0	.061	1500	250.0
	-07	.297	.363	70	70	25.0	.067	1450	230.0
	-08	.351	.429	70	70	25.0	.073	1400	220.0
	-09	.423	.517	70	70	25.0	.080	1350	210.0
	-10	.504	.616	70	70	25.0	.093	1300	200.0
	-11	.612	.748	70	70	25.0	.093	1250	173.0
	-12	.738	.902	70	65	25.0	.100	1200	150.0
	-13	.900	1.10	70	65	25.0	.110	1100	130.0
	-14	1.08	1.36	55	50	7.90	.130	1000	120.0
	-15	1.35	1.65	50	45	7.90	.140	1000	110.0
	-16	1.62	1.98	50	40	7.90	.200	900	100.0
	-17	1.98	2.45	50	40	7.90	.260	800	88.0
	-18	2.43	2.97	52	45	7.90	.380	700	83.0
	-19	2.97	3.63	55	45	7.90	.510	600	78.0
	-20	3.51	4.29	50	50	7.90	.700	500	71.0
	-21	4.23	5.17	50	50	7.90	.880	400	64.0
	-22	5.04	6.16	50	52	7.90	1.30	360	58.0
	-23	6.12	7.48	55	55	7.90	1.70	280	52.0
	-24	7.38	9.02	55	55	7.90	1.90	270	46.0
	-25	9.00	11.0	55	55	7.90	2.00	260	40.0
	-26	10.8	13.6	55	60	2.50	2.10	255	10.5
	-27	13.5	16.5	60	70	2.50	2.20	250	10.0
	-28	16.2	19.8	60	70	2.50	2.30	240	9.5
	-29	19.8	24.5	65	70	2.50	2.50	230	9.0
	-30	24.3	29.7	65	70	2.50	2.70	220	8.5
	-31	29.7	36.3	65	70	2.50	3.00	210	8.0
	-32	35.1	42.9	60	65	2.50	3.50	200	7.5
	-33	42.3	51.7	55	60	2.50	3.60	190	6.4
	-34	50.4	61.6	50	55	2.50	4.00	180	5.7
	-35	61.2	74.8	50	55	2.50	4.30	170	4.9
	-36	73.8	90.2	45	50	2.50	6.40	160	4.6
	-37	90.0	110.0	45	45	2.50	8.50	150	4.3
	-38	108.0	136.0	45	50	.790	9.30	145	3.8

Technical Data Sheet

Basic Part No.	XX	Inductance L (μH)		Q Min. @	Q Min. @	Test Freq. (MHz)	DCR Max. (Ω)	DC Max. (mA)	SRF Min. (MHz)
		Min.	Max.	L Min	L Max				
558-7107	-39	135.0	165.0	50	60	.790	10.0	140	3.5
	-40	162.0	198.0	50	60	.790	11.0	130	3.3
	-41	198.0	245.0	50	60	.790	12.0	120	3.1
	-42	243.0	297.0	50	55	.790	22.0	90	2.9
	-43	297.0	363.0	45	50	.790	23.0	85	2.7
	-44	351.0	429.0	45	50	.790	26.0	80	2.3
	-45	423.0	517.0	40	45	.790	28.0	75	1.9
	-46	504.0	616.0	35	45	.790	33.0	65	1.7
	-47	612.0	748.0	35	40	.790	39.0	60	1.5
	-48	738.0	902.0	30	35	.790	49.0	55	1.3
	-49	900.0	1100.0	30	35	.790	60.0	55	1.2

Core and Cup Core Material is:-

- 01 thru -13 Carbonyl SF (Blue)
- 14 thru -25 Carbonyl TH (Purple)
- 26 thru -37 Carbonyl E (Red)
- 38 thru -49 Carbonyl C (Yellow)

Windings are varnish impregnated and powdered iron components are moisture proofed

Temperature range: -55°C to +105°C

Dimensional Tolerance (unless otherwise stated) - ± .005 (0,13)

Recommended tuning tool - 435-1522-01-00-00