

571-4267 Insulated solder terminal, Slotted, Feed thru

Recommended mounting hole .203 (5,16)

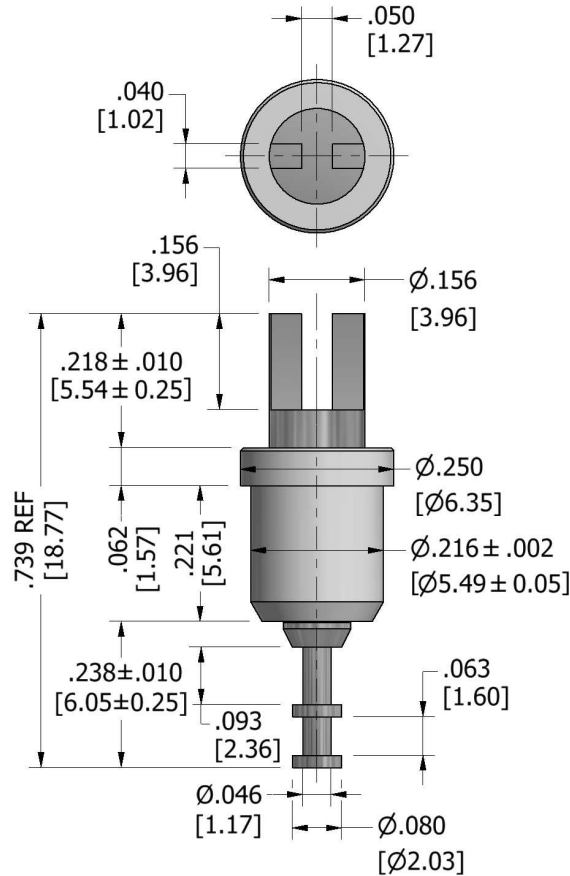

How to order code

571-4267-01-YY-19

Basic Part No (XX = panel thickness, YY = plating finish. See tables for options)

Basic Part No.	Panel Thickness (XX)
571-4267-01	.062 (1,59) to .125 (3,18)

Component	Material	Finish (YY)	
		-01	-05
Terminal	Brass	Silver	Electro Solder
Insulator	PTFE - white		

Additional Specifications	
Flashover VRMS at Sea Level	4100
Capacitance (pF)	0.6

Tolerances unless otherwise stated ±.005 [0.13]