

571-5198, Insulated solder terminal, Feed thru, Wire Wrap, .113 (2,87) mounting hole

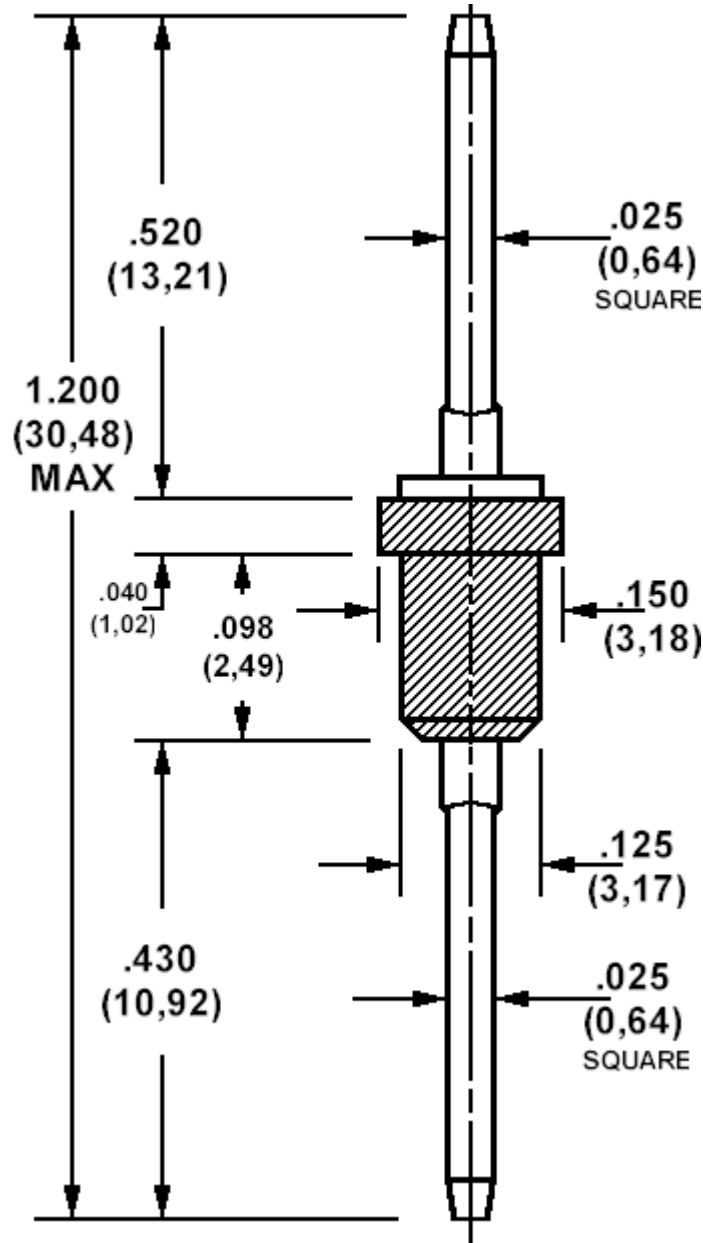

How to order code
571-5198-XX-YY-19

Basic Part No (XX = Panel thickness, YY = plating finish. See tables for options)

Basic Part No.		L	Panel Thickness (XX)
571-5198	-01	.098 (2,49)	.031 (0,79) to .062 (1,59)

Technical Data Sheet

Component	Material	Finish (YY)
		-03
Terminal	Brass	Gold
Insulator	Teflon - white	

Additional Specifications	
Flashover VRMS at Sea Level	3000
Capacitance (pF)	0.4

Mechanical tolerance unless otherwise stated $\pm 0.005(0,13)$

Teflon is a registered trademark of Dupont